

LOGSET 8H GT

AGILE SIX-WHEELED HARVESTER

The Logset 8H GT is an agile and powerful harvester that turns very easily. It is slightly shorter and lighter than the eight-wheeled harvester model Logset 8H GTE. The Logset 8H GT is suitable for thinning operations, but it performs even better on medium and large-sized clear-fells. This harvester model enjoys a solid reputation for unbeatable productivity and fuel economy. The powerful 7.4-liter AGCO Power engine develops 220 kW (300 hp), and in combination with the Mesera M240H crane, this is the perfect machine for challenging felling operations.

COMPONENTS IN BALANCE

The 7.4-litre engine with 220 kW (300 hp), the hydraulics and the mechanical parts of the machine are all perfectly dimensioned for this six-wheeled harvester. The harvester is equipped with the reliable Mesera 240H crane. The outreach of the crane is up to 11,1 meters. The Logset 8H GT is multifunctional and performs well in forests with small, medium and large diameter trees. From the TH harvester head series, the following harvester heads are generally mounted on the Logset 8H GT: TH55, TH65 and TH75. All harvester heads in the TH-series are designed for easy and precise operation.

ECONOMIC

With the six-cylinder AGCO diesel engine, the Logset 8H GT is guaranteed to be the most economic choice compared to other harvesters in its size class. Due to the successful combination of engine size, hydraulics and the new Logset TOC-MD 2, the engine is not strained and the operator will notice this clearly in the low fuel consumption.



8H GT

Harvester range 12/17 - EN
We reserve the right to make changes without prior notice.
All technical specifications are for guidance only.
The pictures and diagrams do not always show standard versions of the machines.
Copyright Logset Oy.



LOGSET

LOGSET Oy
Hännisentie 2
FI-66530 Koivulahti
FINLAND
Tel. +358 10 286 3200

LOGSET
SIMPLY BETTER
www.logset.com

SIMPLY BETTER

LOGSET

Key features of the Logset harvester

ENGINE

The powerful AGCO Power engines with SCR technology deliver high torque at low engine speed, offering the best fuel economy in their range. The Logset 8H GT has a 7.4 l AGCO engine with 220 kW (300 hp). This engine model offers an adequate pump capacity for both crane and harvester head with either a single 210 cc work pump or a double work pump option with respectively 190+140 cc.

CABIN

The cabin has excellent all-round visibility. The upgraded work light guard protects the work lights and cabin roof even better. The new design decreases the transportation height and gives the cabin an eye-pleasing, elegant profile. The cabin's low noise level is a key factor for the operator's comfort.

CRANE

All Mesera cranes have an optimal geometry. The Mesera 240H crane on the Logset 8H GT has an outreach of up to 11.1 meters. It has great lifting power, low gravity point, unique geometry and maximized visibility due to the narrow crane pillar.

CONTROL SYSTEM TOC-MD 2

Logset's own TOC-MD 2 measuring device for the harvester head maximizes the production and is easy to navigate and to use. The technology is thoroughly proven through the years. Features such as the adaptive feeding and cutting window search are making the operator's work easier and the machine more productive.



FUEL AND HYDRAULIC TANKS

The total volume of the fuel tank is 520 litres, which is large compared to other harvesters in this size class. The operator gets more productive time in the forest. The fuel tank and the hydraulic tank can be tilted to the side when access to the hydraulic pumps is required for service.

TRANSMISSION

The transmission is controlled and optimized by the TOC 2 control system. The combination of reliable NAF-bogies and a powerful frame lock system which uses large hydraulic cylinders ensure the perfect stability of the harvester. Hydraulically or mechanically balanced bogies are available as optional equipment.

HYDRAULICS

The Logset 8H GT offers 315 l/min at 1500 rpm with the single work pump, or 495 l/min at 1 500 rpm with the double work pump. Both options offer the correct flow for this machine model to reach high productivity and excellent fuel economy. The right balance for the best output.

HARVESTER HEAD

The Logset TH harvester head is the key to higher productivity. The Logset 8H GT can be equipped with TH55, TH65 or TH75 harvester head, whichever size best meets the needs.

Technical data



MODEL	8H GT
DIMENSIONS	
Own weight, kg from	19 000 (41 800 lbs)
ENGINE	
Type	AGCO Power 74 AWF
Stage	EU Stage IV / EPA Tier 4 final
Power at 1900 rpm, kW	220 (300 hp)
Torque at 1500 rpm, Nm	1 200 (885 ft lb)
Fuel tank, l	520 (137 US gal)
DEF, l	27 (7 US gal)
TRANSMISSION	
Type	hydrostatic mechanical
Tractive effort, kN	169 (37 900 lbf)
Gear box	2 gears
HYDRAULIC SYSTEM	
Flow 1000 rpm, l/min	210 (55 US gal)
Hydraulic oil tank, l	240 (63 US gal)
CABIN	
Control system	TOC 2
Measuring device	TOC-MD 2
Battery voltage	24 V
Safety tested and approved cabin • Rotating and levelling cabin (in option)	
TYRES	
Front	600/55-26.5; 710/45-26.5
Rear	600/65-34; 700/55-34
CRANE	
Crane options	Mesera 240H
Lifting capacity, kNm	240 (177 020 ft lb)
Reach options, m	10.3/11.1 (34/36 ft)
HARVESTER HEADS	
Model options	TH55, TH65, TH75
OPTIONAL EQUIPMENTS	Contact your local dealer for more information about options

LOGSET 8H GT

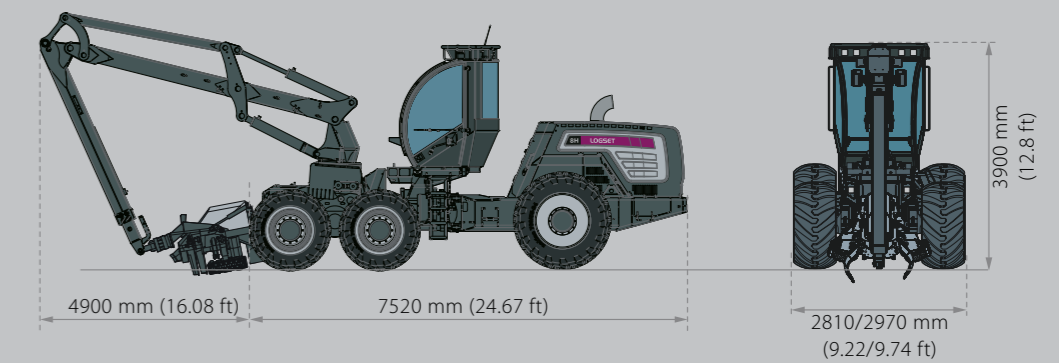

SIMPLY BETTER

LOGSET